



Mini RX

Installation Data

1 INTRODUCTION

- The Mini RX can be used in a wide range of applications due to the large selection of I/O options available.

The Mini RX consists of a Mini Remote Control Station. Each model comes equipped with up to two SmartStack I/O boards, which are factory-installed. The models vary according to the type of I/O board installed and are available in non-network and network versions. Network versions contain an additional connector allowing connectivity to CAN networks.

NOTE: Refer to the SmartStack datasheet(s) sent with your product for wiring and other pertinent information regarding I/O.

1.1 Additional References

For detailed hardware issues including panel cutout information, refer to the current edition of the *MiniOCS / MiniRCS Hardware Manual (MAN0305)*. (See Technical Assistance in Section 5.)

2 INSTALLATION

2.1 Mini RX Mounting Requirements

2.1.1 Mini RX Mounting Procedures (Installed in a Panel Box)

The Mini RX is designed for permanent installation in a panel box. *To install the Mini RX in a panel box, use the instructions that follow:*

1. Prior to mounting the Mini RX, observe requirements for the panel layout design and adequate clearances. A checklist is provided *MiniOCS / MiniRCS Hardware Manual (MAN0305)*.
2. Drill holes as described in the Figure 1.

Warning: Make sure the power and network connectors are removed from the Mini RX.

3. Install and tighten washers and nuts. Do not over-tighten.
4. Connect the communications and power cables to the Mini RX ports using the provided connectors.
5. Begin configuration procedures for the Mini RX models.

2.1.2 Mini RX Dimensions and Panel Cut-outs

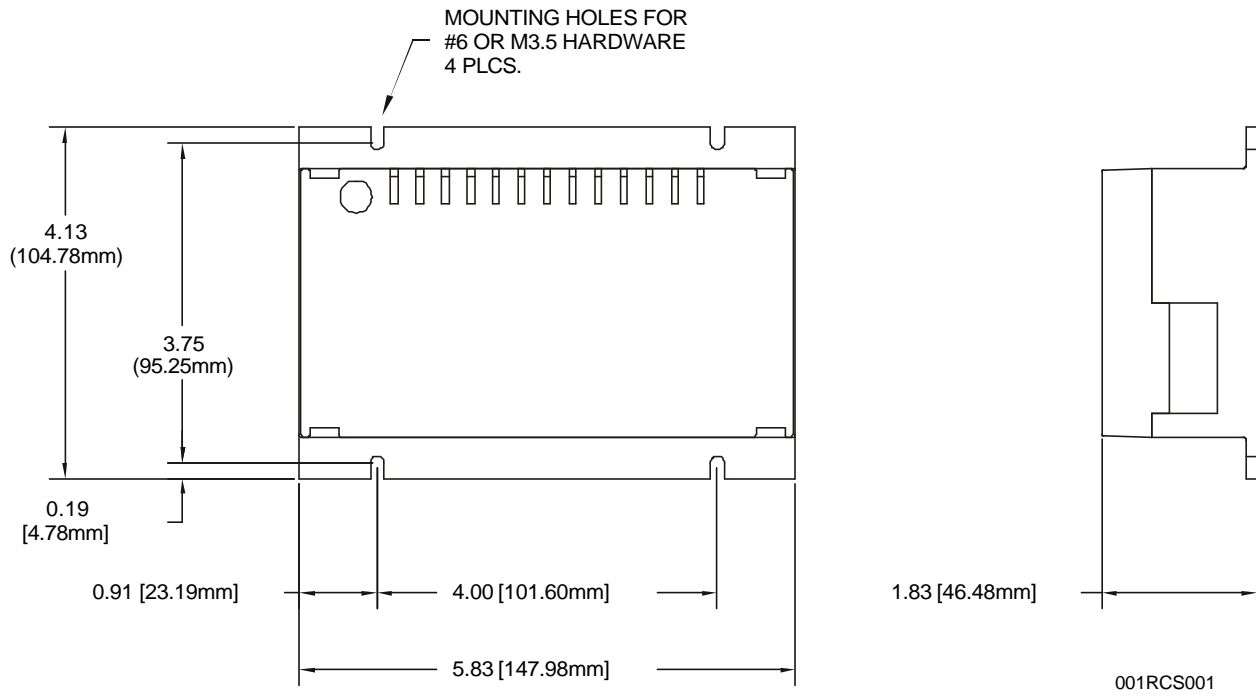



Figure 1 – Mini RX Dimensions / Mounting Holes and Mini RX Side View

2.3 Power, Network, and Programming Ports

The Mini RX Power, Network, and Programming Ports are shown in Figures 2 - 7 for both the network and non-network versions of the Mini RX. The Mini RX I/O Module receptacle is located on the bottom.

2.3.1 Primary Power Port

Table 1 – Primary Power Port Pins		
Pin	Signal	Description
1		Frame Ground
2	V+	Input power supply voltage
3	V-	Input power supply ground

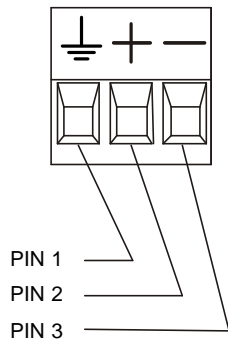

Figure 2 - Power Connector (Primary Power Port) (Front and Side Views Shown)

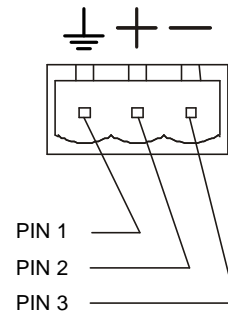

Figure 3 - As viewed looking at the Mini

Note: Power Supply Voltage Range is from 10-30 VDC.

Warning: To provide maximum noise immunity and to insure minimum EMI radiation, the V-signal (DC power return) need to be connected to earth ground at the power supply. The user must ensure that the power supply selected is compatible with this method of grounding.

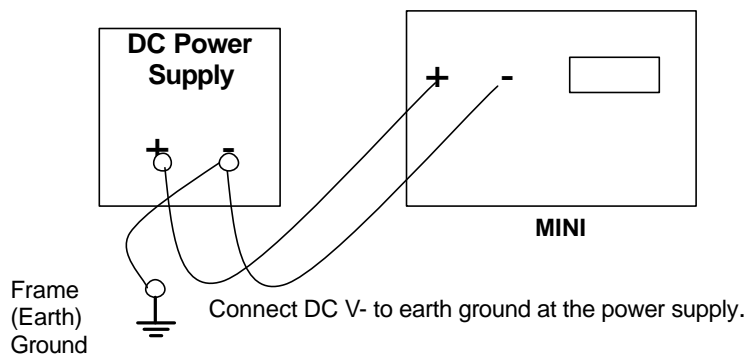

Figure 4 - Grounding

2.3.2 CAN Network / DeviceNet Network Port and Wiring

Pin	Signal	Description
1	V-	Power -
2	CN_L	Signal -
3	SHLD	Shield
4	CN_H	Signal +
5	V+	Power +

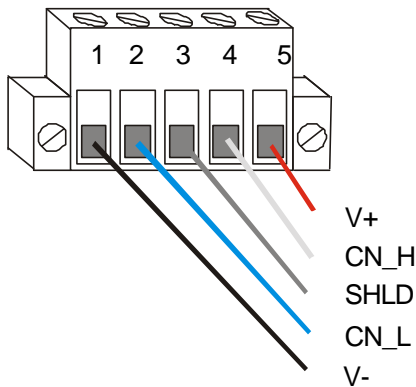

Figure 5 – Network Connector (CAN Port)

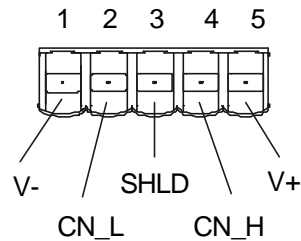

Figure 6 – As viewed looking at the Mini

2.3.3 RS-232 Programming Port and Wiring

Pin	Signal	Description	Direction
1	DCD	Always high	Out
2	RXD	Received Data	Out
3	TXD	Transmitted Data	In
4	DTR	Data Terminal Ready	In
5	GND	Ground	-
6	DSR	Data Set Ready	Out
7	RTS	Request to Send	In
8	CTS	Clear to Send	Out
9	RI	Ring Indicate	Out

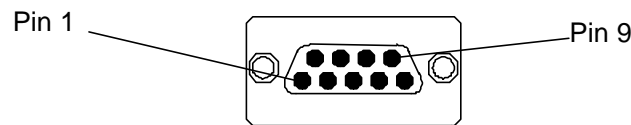

Figure 7 – RS-232 Port

a. RS-232 Communications Wiring

The Mini RX features an RS-232 port (Programming/Debug) for connection to a personal computer. This port is used for the purposes of Mini RX programming, configuring, monitoring, and debugging. This port can also be used for general ladder logic controlled serial communications to printers, modems, terminals, etc. When ladder has control of this port, it is not available for programming or debugging. The wiring diagram for the RS-232 ports is shown in Figure 8. For connection between the Mini RX and the PC, the use of a shielded, multiple conductor wire with a maximum length of 15.24 meters (50 feet) enables proper performance.

Note: A shorter cable can be required when used for high-speed Mini RX firmware updating.

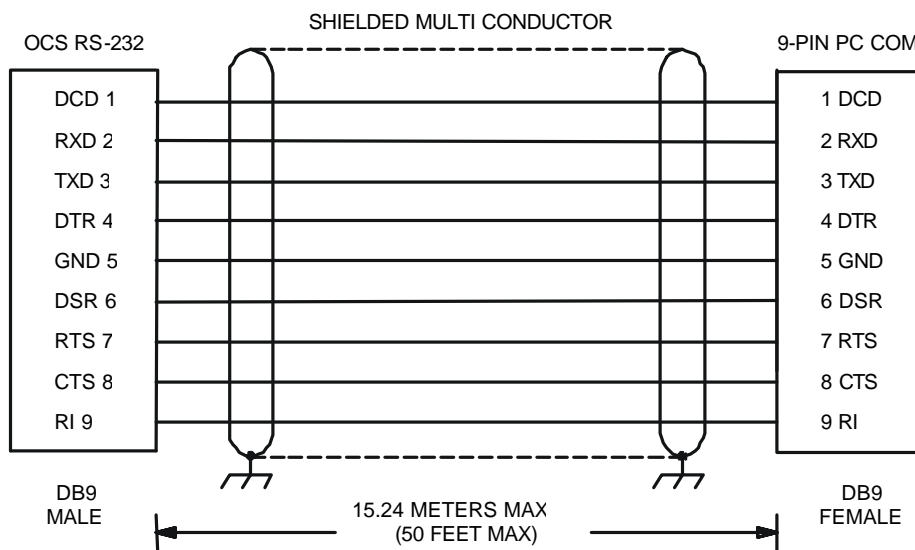

Figure 8 – RS-232 Wiring

3 SAFETY



WARNING!: To avoid the risk of electric shock or burns, always connect the safety (or earth) ground before making any other connections.

WARNING!: To reduce the risk of fire, electrical shock, or physical injury it is strongly recommended to fuse the voltage measurement inputs. Be sure to locate fuses as close to the source as possible.

WARNING!: Replace fuse with the same type and rating to provide protection against risk of fire and shock hazards.

WARNING!: In the event of repeated failure, do not replace the fuse again as a repeated failure indicates a defective condition that will not clear by replacing the fuse.

CAUTION: Only qualified electrical personnel familiar with the construction and operation of this equipment and the hazards involved should install, adjust, operate, or service this equipment. Read and understand this manual and other applicable manuals in their entirety before proceeding. Failure to observe this precaution could result in severe bodily injury or loss of life.

Adhere to the following safety precautions whenever any type of connection is made to the module.

Connect the green safety (earth) ground first before making any other connections.

When connecting to electric circuits or pulse-initiating equipment, open their related breakers. Do not make connections to live power lines.

Make connections to the module first; then connect to the circuit to be monitored.

Route power wires in a safe manner in accordance with good practice and local codes.

Wear proper personal protective equipment including safety glasses and insulated gloves when making connections to power circuits.

Ensure hands, shoes, and floor are dry before making any connection to a power line.

Make sure the unit is turned OFF before making connection to terminals. Make sure all circuits are de-energized before making connections.

Before each use, inspect all cables for breaks or cracks in the insulation. Replace immediately if defective.

All applicable codes and standards need to be followed in the installation of this product.

4 TECHNICAL ASSISTANCE

For technical manual updates and assistance, contact Technical Support at the following locations:

North America:

(317) 916-4274

www.heapg.com

email: techspt@heapg.com

Europe:

(+) 353-21-4321-266

www.horner-apg.com

techsupport@hornerirl.ie