

MANUAL

# Universal Transmitter Power Supply KF\*\*-CRG2-(Ex)1.D

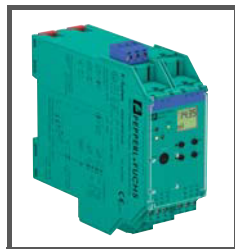

With regard to the supply of products, the current issue of the following document is applicable: The General Terms of Delivery for Products and Services of the Electrical Industry, published by the Central Association of the Electrical Industry (Zentralverband Elektrotechnik und Elektroindustrie (ZVEI) e.V.) in its most recent version as well as the supplementary clause: "Expanded reservation of proprietorship"

<b>1</b>	<b>Symbols used</b> .....	<b>3</b>
<b>2</b>	<b>Overview</b> .....	<b>3</b>
<b>2.1</b>	<b>Range of application</b> .....	<b>3</b>
<b>2.2</b>	<b>Model variants</b> .....	<b>4</b>
<b>3</b>	<b>Safety instructions</b> .....	<b>5</b>
<b>4</b>	<b>Explosion protection</b> .....	<b>6</b>
<b>5</b>	<b>Installation and connection</b> .....	<b>6</b>
<b>5.1</b>	<b>Installation</b> .....	<b>6</b>
<b>5.2</b>	<b>Connection</b> .....	<b>7</b>
5.2.1	Connection input (field circuit) .....	8
5.2.2	Connection output .....	9
<b>5.3</b>	<b>Field device communication via HART</b> .....	<b>10</b>
<b>5.4</b>	<b>Front side</b> .....	<b>10</b>
<b>6</b>	<b>Display modes and error messages</b> .....	<b>11</b>
<b>7</b>	<b>Editing device data</b> .....	<b>12</b>
<b>7.1</b>	<b>Parameterization mode</b> .....	<b>12</b>
7.1.1	Invocation .....	12
7.1.2	Password .....	13
7.1.3	Navigation method .....	14
7.1.4	Lowest menu level: select values, enter numeric values .....	15
<b>7.2</b>	<b>Unit</b> .....	<b>16</b>
<b>7.3</b>	<b>Input</b> .....	<b>17</b>
7.3.1	Line monitor .....	18
7.3.2	Zero point and Conversion factor .....	18
7.3.3	Linerization .....	22
7.3.4	Smoothing .....	22

<b>7.4</b>	<b>Relays</b> .....	<b>23</b>
7.4.1	Operating behaviour .....	24
7.4.2	Trip and Hysteresis .....	26
7.4.3	Alarm freeze .....	26
7.4.4	Delay .....	26
<b>7.5</b>	<b>Current output</b> .....	<b>28</b>
7.5.1	Characteristic .....	29
7.5.2	Fault current .....	31
7.5.3	Start value and End value .....	31
<b>7.6</b>	<b>Service</b> .....	<b>32</b>
<b>7.7</b>	<b>Default settings</b> .....	<b>33</b>

## 1 Symbols used



Warning

*This symbol warns of possible danger.*

*Failure to heed this warning may result in personal injury or death, or property damage, including destruction.*



Attention

*This symbol warns the user of a possible fault.*

*Failure to heed this warning can lead to total failure of the device and any other connected equipment.*



Note

*This symbol draws attention to important information.*

## 2 Overview

### 2.1 Range of application

The K-System devices from Pepperl+Fuchs are used for transmitting signals between field devices and a process control system/control system.

The devices marked with "Ex" in the type designation are suitable for the connection of field devices used in potentially explosive atmospheres. Safe field circuits for these devices are intrinsically safe and are galvanically isolated from non-intrinsically safe circuits. The devices thus establish an electromagnetic separation between the potentially explosive atmospheres and the safe areas in a system.

Devices without Ex-identification can be used to transmit signals between field devices and the process control system/control unit.

Transmitters are measuring units that provide an output signal consisting of a unit current signal (4 mA ... 20 mA). A transmitter power supply provides a transmitter with power and processes the current signal.

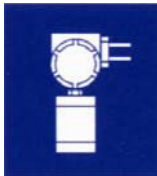

The K-System Universal Transmitter Power Supply KF\*\*-CRG2-(Ex)1.D (CRG2 in short) converts a fully parameterizable partition of input signal in a proportional output current (4 mA ... 20 mA).

This output signal will be transferred to indicators or to analogue inputs on the process control system/control system, for example.

Both relay outputs of CRG2 can monitor two fully parameterizable trip values of the input signal.

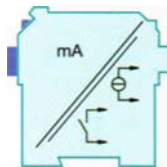

More information (for example, certificates and data sheets for the CRG2 and the operating manual for the K-System) can be found on our webpage [www.pepperl-fuchs.com](http://www.pepperl-fuchs.com) (enter "CRG2" in the product search).

## 2.2 Model variants

The following variants of the Universal Transmitter Power Supply are available:

KF\*\*-CRG2-\*\*1.D

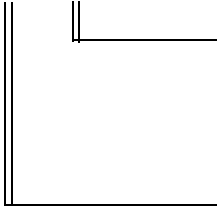

Ex = for connection of field devices in areas exposed to danger of explosion

without identifier letters = for connection of field devices in the safety area

D2 = with a 24 V DC supply (green identification on output side); for power supply via Power Rail with collective error message; please see data sheets and operating manual for the K-System. This information can be found on our webpage [www.pepperl-fuchs.com](http://www.pepperl-fuchs.com) (enter "CRG2" in the product search)

U8 = with an AC/DC wide range supply providing power supply at 20 V DC ... 90 V DC and 48 V AC ... 253 V AC without selection and without notice of polarity (grey identification on output side)

### 3 Safety instructions



Warning

*The Universal Transmitter Power-Supply KF\*\*-CRG2-(Ex)1.D may only be operated by trained professionals in a manner corresponding to this operating manual.*



Warning

*The protection of operating personnel and of the system is only ensured if the devices are used in accordance with their intended purpose. Any other type of operation than that described in this manual places the safety and functionality of the devices and systems connected to them in question.*



Warning

*The devices may only be installed, connected, and adjusted by electrical professionals **outside the hazardous area.***



Warning

*If faults cannot be eliminated, the devices must be taken out of operation and protected from being placed in service again inadvertently. Devices must only be repaired directly by the manufacturer Pepperl+Fuchs. Tampering with or making changes to the devices is dangerous and therefore not permitted. They render the warranty void.*



Note

*The responsibility for the adherence to local safety standards lies with the operator.*

## 4 Explosion protection

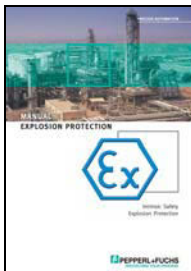

For primary explosion protection, that is, for measures to be taken to prevent or hinder the development of a dangerous explosive atmosphere, please observe the guideline 94/9/EC or the corresponding national guidelines.

For secondary explosion protection, that is, for measures to hinder the ignition of a surrounding explosive atmosphere by electrical devices, Pepperl+Fuchs will gladly make the "Explosion Protection Manual" available to you for a nominal free.

Note in particular EN 60079-0, EN 60079-11, EN 60079-15 and EN 60079-26, or the corresponding national guidelines.

Pepperl+Fuchs also offers a seminar on the topic of explosion protection.

## 5 Installation and connection

### 5.1 Installation



Attention

*The Universal Transmitter Power-Supply KF\*\*-CRG2-(Ex)1.D is constructed in protection degree IP20 and must therefore be protected from undesirable ambient conditions (water, small foreign objects).*



The devices of the K-system from Pepperl+Fuchs and thus also the Universal Transmitter Power-Supply KF\*\*-CRG2-(Ex)1.D can be mounted on a 35 mm standard rail corresponding to DIN EN 50022. The devices must be snapped onto the rail **vertically**, and never slanted or tipped to the side.

Additional possibilities for mounting, e. g. using the Power Rail, can be found in the data sheets and in the K-System operating manual on our webpage [www.pepperl-fuchs.com](http://www.pepperl-fuchs.com) (enter "CRG2" in the product search).



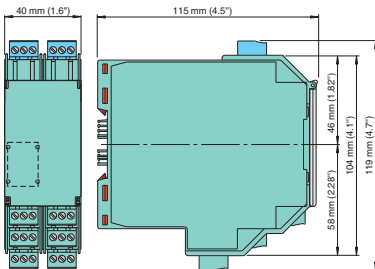

Dimensions of the  
KF\*\*-CRG2-(Ex)1.D in mm

## 5.2 Connection

The removable terminals of the KF-series considerably simplify the connection and the switch cabinet assembly. They make it possible to replace devices quickly and without error if a customer service becomes necessary.

Terminals are equipped with screws, are self-opening, have a large connection area for a wire cross-section up to 2.5 mm<sup>2</sup> and coded plugs, making it impossible to mix them up.



### 5.2.1 Connection input (field circuit)

The intrinsically safe field circuit is connected to the **blue** terminals 1 to 3 on the KF\*\*-CRG2-Ex1.D. This may be conducted using DIN EN 60079-14-compliant leads into the hazardous area.

The non-intrinsically safe field circuit is connected to the **green** terminals 1 to 3 on the KF\*\*-CRG2-1.D.

In both cases you can connect the following field devices:

1. a 3-wire transmitter
2. a 2-wire transmitter with HART
3. an active current source

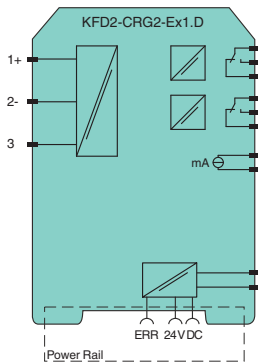
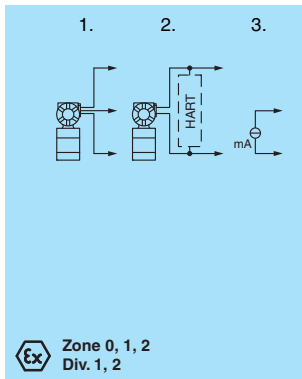

### 5.2.2 Connection output

The control circuit and the power supply are connected to the **green** terminals 7 to 24 on the KF\*\*-CRG2-(Ex)1.D.

The terminals have the following functions:

- Terminals 7/8: current output (terminal 9 not used)
- Terminals 10 ... 12: relay 1
- Terminals 16 ... 18: relay 2
- Terminals 23/24: (terminal 22 not used)
  - KFD2: 24 V DC power supply
  - KFU8: AC/DC power supply

Terminals 4 ... 6, 13 ... 15 and 19 ... 21 do not exist on the CRG2.

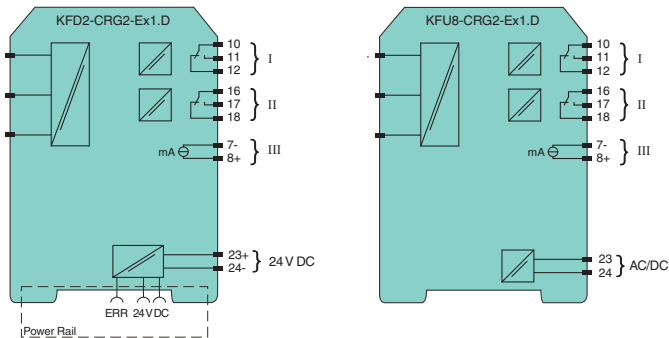

More information on connecting the CRG2 (e. g. using the Power Rail) can be found in the data sheets and the K-System operating manual on our webpage [www.pepperl-fuchs.com](http://www.pepperl-fuchs.com) (enter \*CRG2\* in the product search).

### 5.3 Field device communication via HART

In order to set the parameters of the connected HART field device, you will require a HART communicator which you can connect to the field cables. Transmitting the HART signal via the current output of the CRG2 is not possible.



Warning

*When connecting the field cables, use an communicator for hazardous areas if the field cables of CRG2 lead through a hazardous area.*

### 5.4 Front side

The following indicating and operating elements are located on the front of the CRG2:

- LED CHK (red) to indicate a device fault
- LED PWR (green) to indicate the presence of the supply voltage
- LED OUT 1 (yellow) to indicate that relay 1 is active
- LED OUT 2 (yellow) to indicate that relay 2 is active
- Display for indication of the measured values, fault messages and parameterization modi
- Four keys for setting the parameters of the CRG2:  
▲ (Up)      ▼ (Down)      ESC (Escape)      OK
- Interface for connecting a computer for parameterization and diagnostics of the device with the **PACTware™** operating software, using the K-ADP-USB adapter

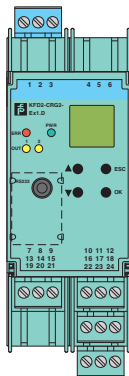

## 6 Display modes and error messages

In normal operation, the current measured value is indicated in the selected unit. For information on selecting the unit, see section 7.2.

If the Alarm freeze (see section 7.4.3) is triggered but the device continues operating normally, a corresponding message appears in the second line of the display.

If a fault occurs, one of the following messages is displayed until the fault is rectified (when parameterized):

- *Err Mem* for device fault,
- *Err LB* for lead breakage,
- *Err SC* for short circuit

For the selection of error messages see section 7.3.1.

If switching the CRG2 on/off and checking the cables does not rectify the fault, please contact Pepperl+Fuchs or the field device manufacturer.

The relays de-energizes when a fault occurs.

For information on the behaviour of the current output in the event of fault, see section 7.5.2.



Note

*The display of the device is updated at regular intervals. This can causes a short flickering of the display. This flickering isn't a defect of the display.*

## 7 Editing device data



### Warning



### Note

*A change in device data will change the operation of the device!  
Before entering new data into the device, you should ascertain that no danger to the installation will result.*

*In this manual, the parameterisation of the device via the control panel is described.  
Parameterisation by means of a PC is more convenient.*

*The necessary K-ADP-USB can be ordered from Pepperl+Fuchs. The **PACTware™** operating software and the manual are available on our Internet page [www.pepperl-fuchs.com](http://www.pepperl-fuchs.com) under Software > PACTware.*

## 7.1 Parameterization mode

### 7.1.1 Invocation

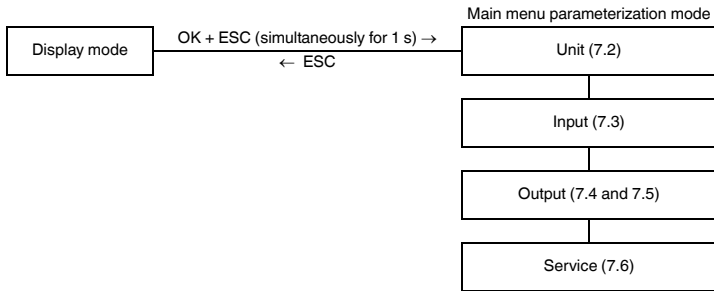

You can return to display mode from any point in the menu in parameterization mode by pressing the ESC key (possibly multiple times). If you do not press any key for 10 minutes in parameterization mode, the device automatically switches back into display mode.

### 7.1.2 Password

You can protect the parameterization from unauthorized changes by means of a password (see section 7.6; at the delivery of the CRG2, the password is inactive).

If the password protection is active, you can view the different settings in the parameterization mode, but not change them before entering the password. On the first attempt to make a change, the device immediately prompts for a password.

The password must be entered for **each** transition from display mode to parameterization mode, **once** each time.

The password cannot be changed. It is **1234**.

The password is entered as follows:

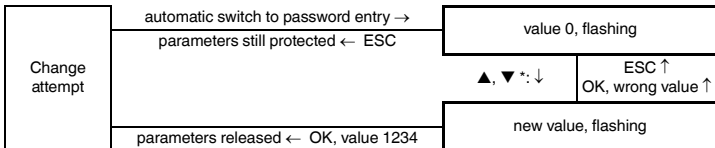

\* If you press the ▲ or ▼ key, the value changes step by step. If you hold the ▲ or ▼ key, the setting "rolls" to higher or lower values.

### 7.1.3 Navigation method

The following diagram shows the navigation method in parameterization mode using the ▲, ▼, OK and ESC keys:

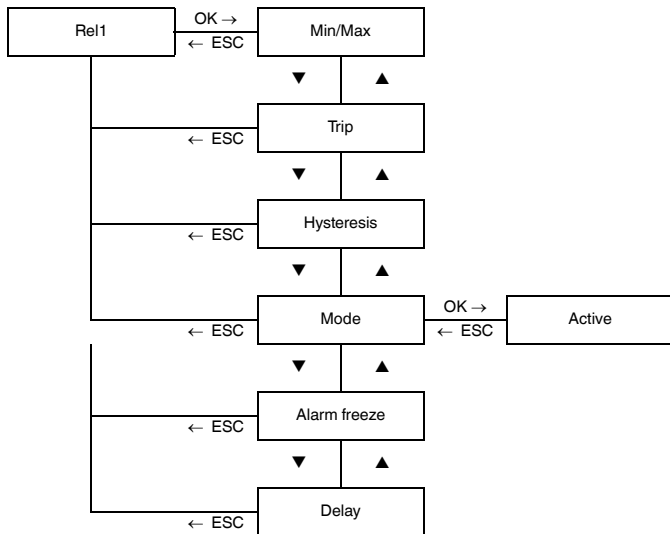



#### 7.1.4 Lowest menu level: select values, enter numeric values

On the lowest level of the menu, you can either select one of several possible values, or enter a number for the individual parameters.

Proceed as follows:

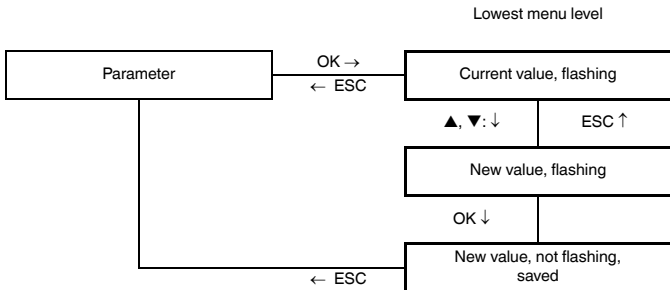

When entering *numeric values*, please note:

- If you press the ▲ or ▼ keys, the value changes step by step.
- If you hold the ▲ or ▼ keys, the value "rolls" to higher or lower values.
- The algebraic sign changes automatically.
- The decimal point is moved automatically.

## 7.2 Unit

The following diagram shows the unit menu. Items from the lowest menu level are outlined in bold.

The CRG2 measures in mA. Using the parameters zero point and conversion factor (section 7.3.2) it converts the measured value into the selected units. These units are used for the display of the measured values and for all corresponding settings in the parameterization mode.

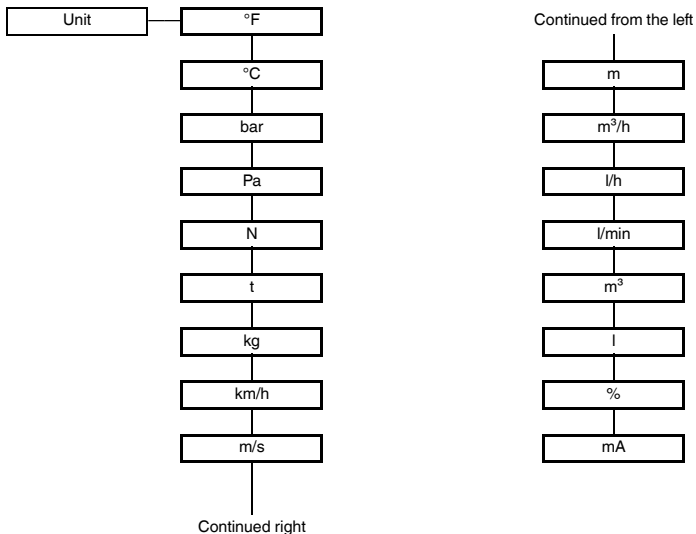

### 7.3 Input

The following diagram shows the input parameters menu. Items from the lowest menu level are outlined in bold.

The menu items *Zero point* and *Conversion factor* will **not** be shown if the unit mA is selected (section 7.2).

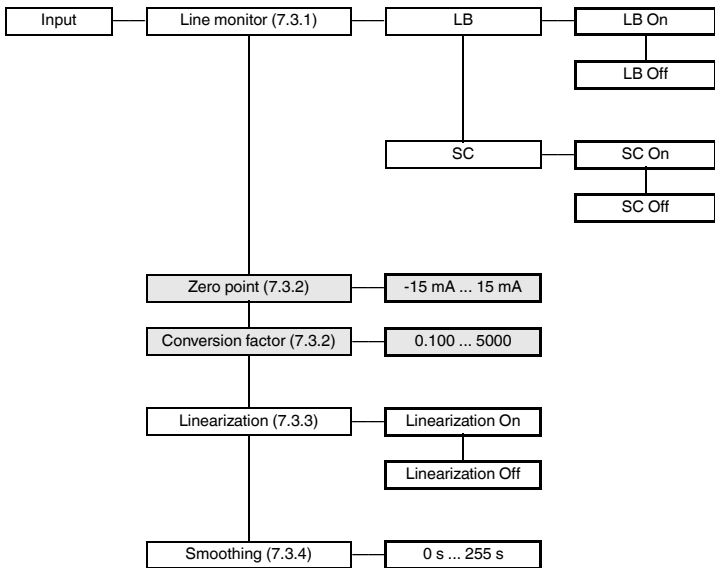

### 7.3.1 Line monitor

- If you select *On* for *LB*, an input current < 0.2 mA will be registered as a lead break (section 6).
- If you select *On* for *SC*, an input current > 22 mA will be registered as a short circuit (section 6).

If you wish to process the  $\leq 0.2$  mA input values as measured values, you must deselect the lead breakage detection (*Off LB*). If not, an error will be signalled within the measuring range.

### 7.3.2 Zero point and Conversion factor

The device measures in mA. If you have selected different *units* (section 7.2), the device calculates the measured value in the selected units using the parameters *Zero point* and *Conversion factor*.

The parameters for your application must be determined according to the following formula:

**Measured value in the selected units** = (Original measured value [mA] – Zero point) x Conversion factor

An arbitrary value between -15 mA and +15 mA can be set as the *Zero point*, and values between 0.100 and 5000 as the *Conversion factor*.

The following includes examples where the formulas are applied.

**Example 1: selected unit °C, 0 °C ... 200 °C is to correspond to 4 mA ... 20 mA**

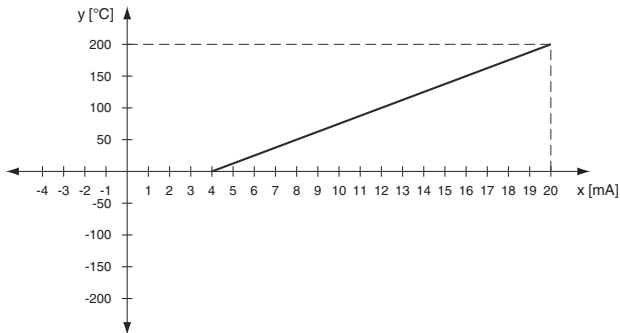

- Linearization  
 $y = m x + n$
- Conversion factor = rise in the graph  
 $m = (y_2 - y_1) / (x_2 - x_1)$   
 $m = (200 - 0) / (20 - 4) = 12.5$
- Zero point = intersection point with the x-axis on the graph, providing that the physical measuring range starts from 0 ( $y = 0$  °C). The zero point corresponds to the lower measuring range limit ( $x = 4$  mA) from which the measuring range starts.

The zero point can be calculated as follows:

$$n = y - m x$$

$$n = 200 - 12.5 \times 20 = -50$$

$$y = m x + n$$

$$x = (y - n) / m$$

$$x = (0 + 50) / 12.5 = 4$$

**Example 2: selected unit °C, 0 °C ... -100 °C is to correspond to 20 mA ... 0 mA**

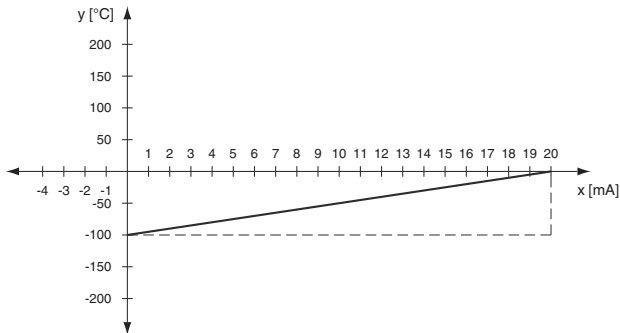

- Linearization  
 $y = m x + n$
- Conversion factor = rise in the graph  
 $m = (y_2 - y_1) / (x_2 - x_1)$   
 $m = (100 - 0) / (20 - 0) = 5$
- Zero point = intersection point with the x-axis on the graph, with the condition that the physical measuring range starts from 0 ( $y = 0$  °C). The zero point corresponds to the upper measuring range limit ( $x = 20$  mA) at which the measuring range ends.

The zero point can be calculated as follows:

$$n = y - m x$$

$$n = -100 - 5 \times 0 = -100$$

$$y = m x + n$$

$$x = (y - n) / m$$

$$x = (0 + 100) / 5 = 20$$

**Example 3: selected unit bar, -4 bar ... 4 bar is to correspond to 4 mA ... 20 mA**

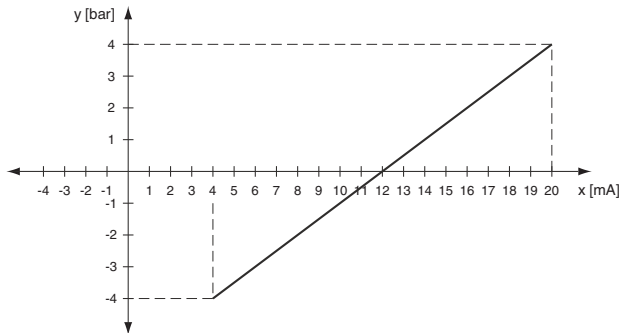

- Linearization  
 $y = m x + n$
- Conversion factor = rise in the graph  
 $m = (y_2 - y_1) / (x_2 - x_1)$   
 $m = (4 - 0) / (20 - 12) = 0.5$
- Zero point = intersection point with the x-axis on the graph (bar value at  $y = 0$ )  
 $n = y - m x$   
 $n = 4 - 0.5 \times 20 = -6$   
 $y = m x + n$   
 $x = (y - n) / m$   
 $x = (0 + 6) / 0.5 = 1$

### 7.3.3 Linerization

Using the parameterization software **PACT<sub>ware</sub>**<sup>TM</sup> a linearization table can be saved in the CRG2; for details of this function see On-line help. Via the operator panel you can merely switch the use of the table for the calculation of the output value on and off (On/Off).

### 7.3.4 Smoothing

For extremely variable measurement values, you can use *Smoothing* to influence how quickly an output reacts to a change in input value: 0 s = no smoothing, 255 s = maximum smoothing.



## 7.4 Relays

The following diagram shows the relay outputs menu. Items from the lowest menu level are outlined in bold.

From the *Rel1* and *Rel2* menu options, you can use the OK key to get to a menu in which you can enter individual parameters for the selected relay. Both menus are structured in the same way and are thus only described once. Information about current output see section 7.5.

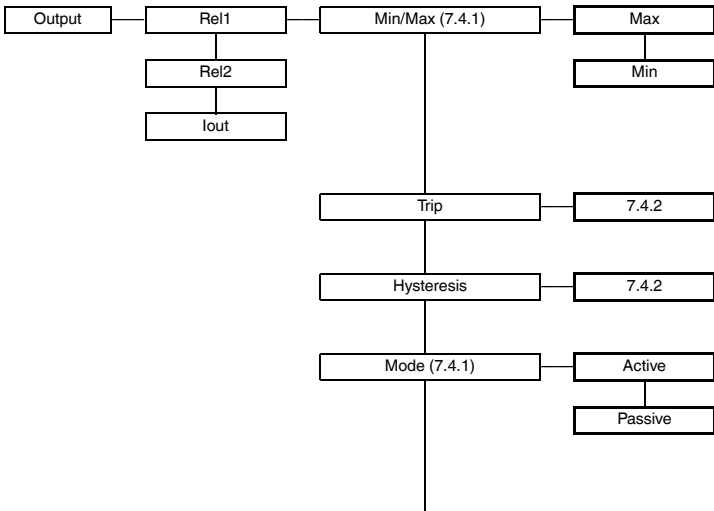

Continued on next page

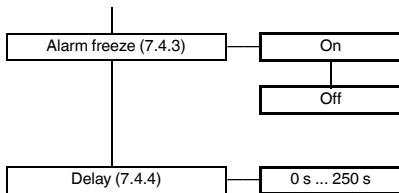

#### 7.4.1 Operating behaviour

The switching direction can be set as *Max* or *Min* and the direction of action as *Active* or *Passive* (section 7.4).

Application ranges:

- Switching direction *Max*, mode of operation *Active*:  
alarm on trip value overrange, e. g. audible alarm on
- Switching direction *Max*, mode of operation *Passive*:  
switch off on trip value overrange, e. g. pump, heating, ... off;  
with large hysteresis Min/Max operation (pump, heating, ... on/off)
- Switching direction *Min*, mode of operation *Active*:  
alarm on trip value underrange, e. g. audible alarm on
- Switching direction *Min*, mode of operation *Passive*:  
switch off on trip value underrange, e. g. pump, heating, ... off;  
with large hysteresis Min/Max operation (pump, heating, ... off/on)

The exact operating behaviour of the CRG2 is shown in the following diagram:

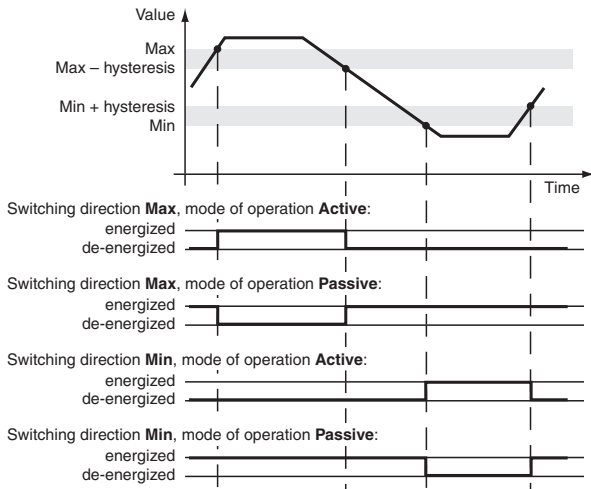

#### 7.4.2 Trip and Hysteresis

When entering the values for *Trip* and *Hysteresis* please note:

- Both values are to be entered in the units, which were selected under *Units* (section 7.2).
- You can enter values
  - between 0 mA and 24 mA and
  - between the converted values of these limits in the selected units; for conversion using the parameters *Zero point* and *Conversion factor* see section 7.3.2
- The hysteresis must be selected as > 1 % of the trip point to prevent the relay from vibrating.
- As the representation of the operating behaviour in section 7.4.1 shows, the following must apply:
  - for the switching direction *Max*: Trip point - Hysteresis  $\geq$  0
  - for the switching direction *Min*: Trip point + Hysteresis  $\leq$  upper limit trip point

These input limits are automatically preset by the CRG2.

#### 7.4.3 Alarm freeze

The *Alarm freeze* helps you to avoid that short-term trip value overranges are not noticed by the operating staff.

If *Alarm freeze On* has been selected, the new state is maintained after the relay switching until the ESC key is pressed or the device is restarted. These actions reset the relay, except for a limit violation.

#### 7.4.4 Delay

If you set a time > 0 sec, you prevent short-time violations of the trip value from triggering an alarm.

- The relay only switches if the trip point is exceeded/fallen short of for a period that is longer than the delay time.
- The relay only switches back if the trip point +/- hysteresis is fallen short of/exceeded for a period that is longer than the delay time.
- If the trip point is exceeded/fallen short of for a short time, this does not have any effects.

The following diagram shows the operating behaviour for the trip mode *Max*, operating mode *Active*.

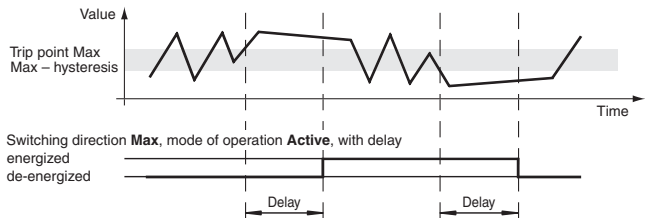

## 7.5 Current output

The following illustrations show the current output menus. Items from the lowest menu level are outlined in bold. Information about relay outputs see section 7.4.

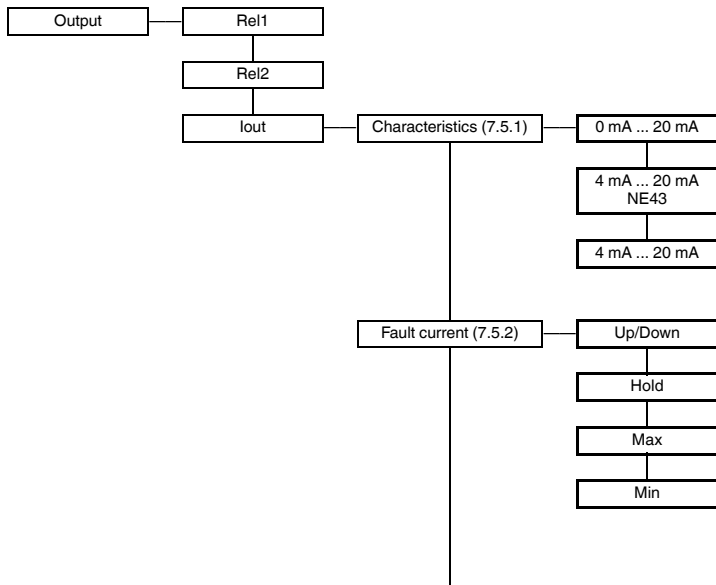

Continued on next page

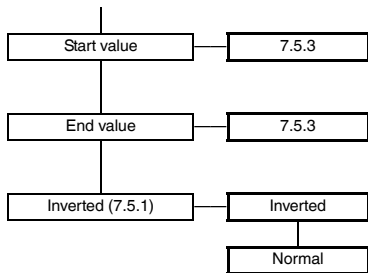

### 7.5.1 Characteristic

With the parameters *Start value* and *End value* establish a sub-range of the input signal as the measuring range of the application (section 7.5.3). This measuring range is formed linearly on the output signal.

The following table shows, for the various characteristics (section 7.5), the conversion of the *Start value* and *End value* and the behaviour during measuring overrange.

- The statements apply for the setting *Inverted* → *Normal*.
- If you select *Inverted* → *Inverted*, the conversion of *Start value* and *End value* are reversed. The start value is thus converted to 20 mA and the end value to 0 mA or 4 mA.
- Measuring overrange, which extend over the described linear range, cannot be evaluated. In the case of such overrange, the specified value is constantly output.

Characteristic	Start value converted into	End value converted into	Linear underrange up to	Linear overrange up to
0 mA ... 20 mA	0 mA	20 mA	0 mA	20.5 mA
4 mA ... 20 mA NE43	4 mA	20 mA	3.8 mA	20.5 mA
4 mA ... 20 mA	4 mA	20 mA	0 mA	approx. 22 mA

### Example of a diagram of a mA measurement range on the output signal

Characteristic 4 mA ... 20 mA NE43, start value 2 mA, end value 10 mA

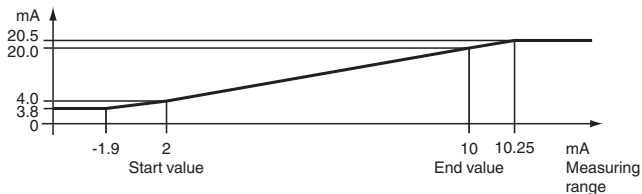

### Example diagram displaying the input signal in °C to the output signal

Characteristic 4 mA ... 20 mA NE43, start value 0 °C, end value 200 °C (see example 1 in section 7.3.2)

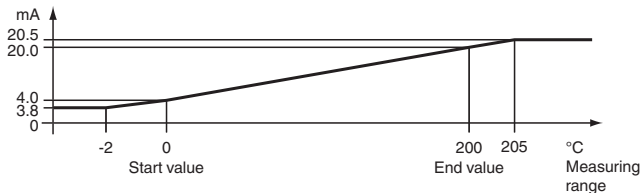



### 7.5.2 Fault current

The following table shows the current output in the event of a fault, depending on the characteristic.

Setting	0 mA ... 20 mA	4 mA ... 20 mA NE43	4 mA ... 20 mA
Up/Down	21.5 mA with short-circuit	21.5 mA with short-circuit	22 mA with short-circuit (not distinguishable from <i>End value</i> overrange)
	0 mA with lead breakage (not distinguishable from <i>Start value</i> measurement)	2.0 mA with lead breakage	0 mA with lead breakage (not distinguishable from <i>Start value</i> underrange)
Hold	Last measured value before the fault		
Max	21.5 mA	21.5 mA	22 mA (not distinguishable from <i>End value</i> overrange)
Min	0 mA (not distinguishable from <i>Start value</i> measurement)	2.0 mA	0 mA (not distinguishable from <i>Start value</i> underrange)

### 7.5.3 Start value and End value

Please note when entering *Start value* and *End value*:

- Both values are to be entered in the units, which were selected under *Units* (section 7.2).
- Values between 0 mA and 20 mA can be entered, or between the values of these limits converted into the selected units, using the parameters *Zero point* and *Conversion factor* see section 7.3.2

The difference between *End value* and *Start value* must be at least 1 % of the *End value* (preset automatically by the CRG2).

## 7.6 Service

The following diagram shows the service parameter menus. Items from the lowest menu level are outlined in bold.

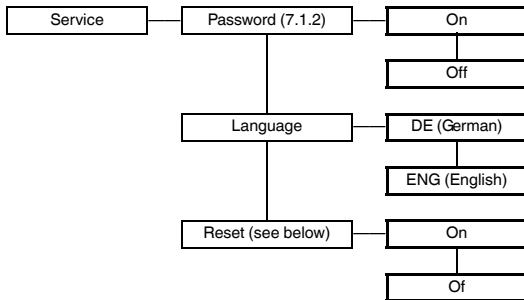

**Reset:** Pressing the OK key when *On Reset* is flashing resets all settings on the CRG2 to default (see section 7.7). Any entries that you have made in parameterization mode are lost.

## 7.7 Default settings

Menu	Parameter	Default setting	Separate value
Main menu	Unit	mA	
Input	Line monitor	On LB/On SC	
	Zero point	4.000 mA	
	Conversion factor	0.100	
	Linearization	Off	
	Smoothing	3 s	
Output Rel1	Min/Max (= switching direction)	Min	
	Trip	16.00 mA	
	Hysteresis	2.000 mA	
	Mode	Passive	
	Alarm freeze	Off	
	Delay	0 s	
Output Rel2	Min/Max (= switching direction)	Min	
	Trip	2.000 mA	
	Hysteresis	2.000 mA	
	Mode	Active	
	Alarm freeze	Off	
	Delay	0 s	
Output Iout	Characteristics	4 mA ... 20 mA NE43	

<b>Menu</b>	<b>Parameter</b>	<b>Default setting</b>	<b>Separate value</b>
	<i>Fault current</i>	<i>Min</i>	
	<i>Start value</i>	<i>0.000 mA</i>	
	<i>End value</i>	<i>20.00 mA</i>	
	<i>Inverted</i>	<i>Normal</i>	
<i>Service</i>	<i>Password</i>	<i>Off</i>	
	<i>Language</i>	<i>ENG</i>	



# PROCESS AUTOMATION – PROTECTING YOUR PROCESS



## Worldwide Headquarters

Pepperl+Fuchs GmbH  
68307 Mannheim · Germany  
Tel. +49 621 776-0  
E-Mail: [info@de.pepperl-fuchs.com](mailto:info@de.pepperl-fuchs.com)

For the Pepperl+Fuchs representative  
closest to you check [www.pepperl-fuchs.com/contact](http://www.pepperl-fuchs.com/contact)

[www.pepperl-fuchs.com](http://www.pepperl-fuchs.com)

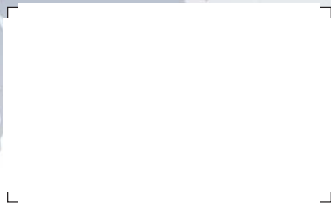

 **PEPPERL+FUCHS**  
*PROTECTING YOUR PROCESS*

Subject to modifications  
Copyright PEPPERL+FUCHS · Printed in Germany

281130

DOCT-1496D

07/2015