

**Features**

- 1-channel isolated barrier
- 24 V DC supply (Power Rail)
- Resistance and RTD input (Pt100, Pt500, Pt1000)
- Resistance output
- Accuracy 0.1 %
- Line fault detection (LFD) for Pt100
- Housing width 12.5 mm
- Up to SIL2 acc. to IEC 61508

**Function**

This isolated barrier is used for intrinsic safety applications. It transfers resistance values of RTDs or potentiometers from hazardous areas to safe areas. A 2-, 3-, or 4-wire technique is available depending on the required accuracy. The input card of the control system measures the same load as if it were connected directly to the resistance in a hazardous area.

**Assembly**

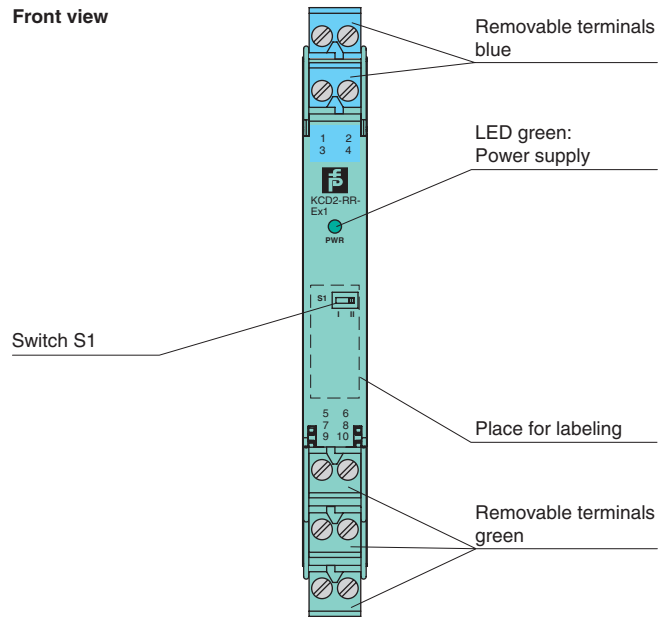

**SIL2**

**Connection**

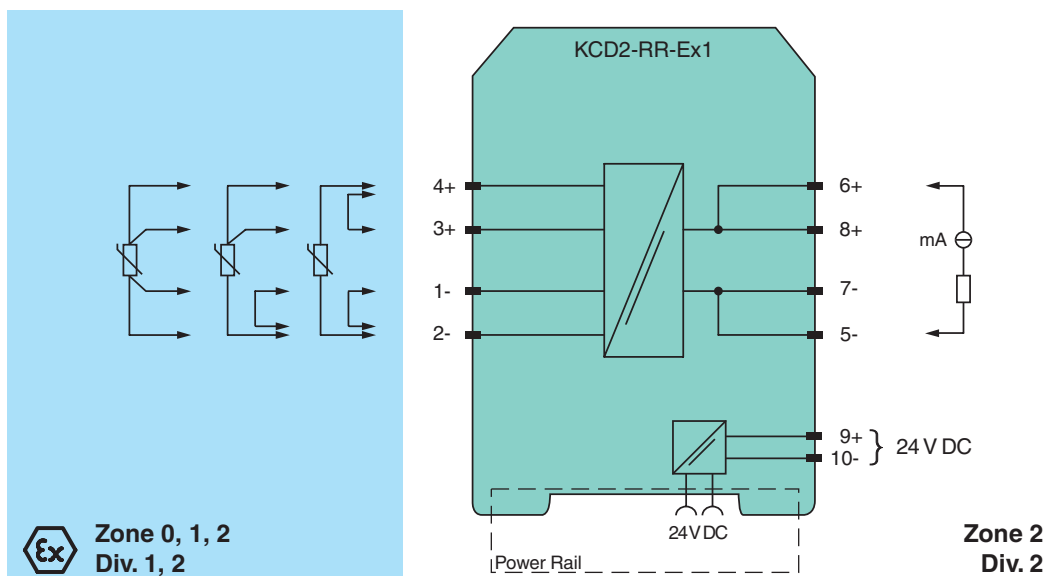

Release date 2015-04-27 13:37 Date of issue 2015-04-27 258075\_eng.xml

Refer to "General Notes Relating to Pepperl+Fuchs Product Information".

<b>General specifications</b>		
Signal type		Analog input
<b>Supply</b>		
Connection		Power Rail or terminals 9+, 10-
Rated voltage	$U_n$	19 ... 30 V DC
Ripple		within the supply tolerance
Rated current	$I_n$	< 20 mA
Power consumption		0.35 W (24 V and 1 mA sense current)
<b>Input</b>		
Connection		terminals 1, 2, 3, 4
Line fault detection		yes, at Pt100
Lead resistance		≤ 10 % of resistance value
Transmission range		0 ... 10 mA
Available voltage		9 V
Line fault detection		8 nA
<b>Output</b>		
Connection		terminals 5-, 7-, 6+, 8+
Current		0 ... 10 mA
Available voltage		0 ... 4.2 V
Fault signal		< 10 Ω or > 400 Ω, depending on lead disconnected (measuring current ≤ 1mA)
<b>Transfer characteristics</b>		
Deviation		4-wire $I_m \geq 1 \text{ mA}$ : ±0.1 % of $R_m$ or ± 0.1 Ω (the larger value is applicable) $I_m < 1 \text{ mA}$ : accuracy reduces in proportion to $I_m$ . e. g. $I_m = 0.1 \text{ mA}$ : ± 1 % of $R_m$ or 1 Ω (the larger value is applicable). 3-wire $I_m \geq 1 \text{ mA}$ : (±0.1 % - 0.1 Ω Offset) or ± 0.2 Ω (the larger value is applicable) $I_m < 1 \text{ mA}$ : accuracy reduces in proportion to $I_m$ . e. g. $I_m = 0.1 \text{ mA}$ : (±1 % - 0.1 Ω Offset) or ± 1.1 Ω (the larger value is applicable)
Influence of ambient temperature		$I_m \geq 1 \text{ mA}$ , $R_m \geq 100 \Omega$ : 0.01 %/K in the range -20 ... +60 °C (253 ... 333 K) $I_m < 1 \text{ mA}$ or $R_m < 100 \Omega$ : temperature stability reduces in proportion to $I_m$ or $R_m$
Rise time		signal response time ≤ 2 ms (10 ... 90 %) response to application of $I_m$ : $R_m > 50 \Omega$ and $I_m < 5\text{mA}$ : < 5ms response to application of $I_m$ : $R_m > 30 \Omega$ and $I_m < 5\text{mA}$ : < 10ms response to application of $I_m$ : $R_m > 18 \Omega$ and $I_m < 5\text{mA}$ : < 20ms
<b>Electrical isolation</b>		
Input/Output		reinforced insulation acc. to EN 50178, rated insulation voltage 300 V <sub>eff</sub>
Input/power supply		reinforced insulation acc. to EN 50178, rated insulation voltage 300 V <sub>eff</sub>
Output/power supply		functional insulation, rated insulation voltage 50 V AC
<b>Directive conformity</b>		
Electromagnetic compatibility		
Directive 2004/108/EC		EN 61326-1:2013 (industrial locations)
<b>Conformity</b>		
Electromagnetic compatibility		NE 21:2011
Degree of protection		IEC 60529:2001
Protection against electrical shock		UL 61010-1
<b>Ambient conditions</b>		
Ambient temperature		-20 ... 60 °C (-4 ... 140 °F)
<b>Mechanical specifications</b>		
Degree of protection		IP20
Mass		approx. 100 g
Dimensions		12.5 x 114 x 124 mm (0.5 x 4.5 x 4.9 in) , housing type A2
Mounting		on 35 mm DIN mounting rail acc. to EN 60715:2001
<b>Data for application in connection with Ex-areas</b>		
EC-Type Examination Certificate		BASEEFA 10 ATEX 0061 , for additional certificates see www.pepperl-fuchs.com
Group, category, type of protection		⊕ II (1)G [Ex ia Ga] IIC ⊕ II (1)D [Ex ia Da] IIIC ⊕ I (M1) [Ex ia Ma] I
Input		[Ex ia Ga] IIC, [Ex ia Da] IIIC, [Ex ia Ma] I
Voltage	$U_o$	12.4 V
Current	$I_o$	17.4 mA
Power	$P_o$	54 mW
<b>Supply</b>		
Maximum safe voltage	$U_m$	253 V (Attention! The rated voltage can be lower.)
<b>Output</b>		
Maximum safe voltage	$U_m$	253 V (Attention! The rated voltage can be lower.)

Release date 2015-04-27 13:37 Date of issue 2015-04-27 258075\_eng.xml

Refer to "General Notes Relating to Pepperl+Fuchs Product Information".

Pepperl+Fuchs Group  
www.pepperl-fuchs.com

USA: +1 330 486 0002  
pa-info@us.pepperl-fuchs.com

Germany: +49 621 776 2222  
pa-info@de.pepperl-fuchs.com

Singapore: +65 6779 9091  
pa-info@sg.pepperl-fuchs.com

Statement of conformity	BASEEFA 10 ATEX 0062X , observe statement of conformity
Group, category, type of protection, temperature class	⊕ II 3G Ex nA II T4 Gc [device in zone 2]
Electrical isolation	
Input/Output	safe electrical isolation acc. to IEC/EN 60079-11, voltage peak value 375 V
Input/power supply	safe electrical isolation acc. to IEC/EN 60079-11, voltage peak value 375 V
Directive conformity	
Directive 94/9/EC	EN 60079-0:2012+A11:2013 , EN 60079-11:2012 , EN 60079-15:2010
<b>International approvals</b>	
FM approval	
Control drawing	116-0129 (cFMus)
UL approval	
Control drawing	116-0332 (cULus)
IECEX approval	IECEX BAS 10.0024 IECEX BAS 10.0025X
Approved for	[Ex ia Ga] IIC, [Ex ia Da] IIIC, [Ex ia Ma] I
<b>General information</b>	
Supplementary information	EC-Type Examination Certificate, Statement of Conformity, Declaration of Conformity, Attestation of Conformity and instructions have to be observed where applicable. For information see <a href="http://www.pepperl-fuchs.com">www.pepperl-fuchs.com</a> .
<b>Accessories</b>	
Designation	optional accessories: insertion bridge EBP 2- 5

Release date 2015-04-27 13:37 Date of issue 2015-04-27 258075\_eng.xml

Refer to "General Notes Relating to Pepperl+Fuchs Product Information".

Pepperl+Fuchs Group  
www.pepperl-fuchs.com

USA: +1 330 486 0002  
pa-info@us.pepperl-fuchs.com

Germany: +49 621 776 2222  
pa-info@de.pepperl-fuchs.com

Singapore: +65 6779 9091  
pa-info@sg.pepperl-fuchs.com

**Additional information**

**Function**

When a signal converter, a DCS or PLC is connected to terminals 5, 6, 7, and 8 (control side), the measuring current is transferred to terminals 2 and 4 (field side). The resulting voltage at terminals 1, and 3 is transferred to terminals 5, 6, 7, and 8. In the case of fast multiplex input cards, transmission problems might be experienced in connection with low resistance values and/or high sensor currents. For data see rise time.

The quoted accuracy is for a 4-wire technique connection. The accuracy in 3-wire technique will depend on the matching of the line resistance.

**Connection types control side (safe area)**

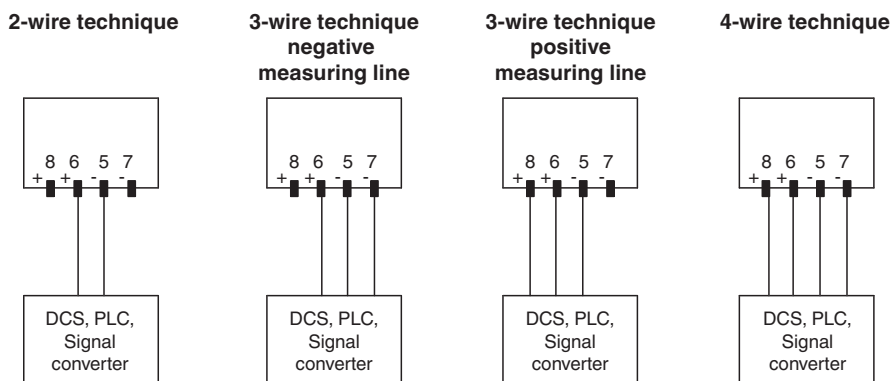

**Connection types field side (hazardous area)**

The resistance in the hazardous area can be measured with a 2-, 3- or 4-wire technique.

- 2-wire technique: Link terminals 1 and 2 and terminals 3 and 4. Connect the resistance to terminal 4 and terminal 2. Switch S1 in the position II.
- 3-wire technique: Link terminals 1 and 2. Connect the resistance to terminals 3 and 4 and terminal 2. Switch S1 in the position I.
- 4-wire technique: Connect the resistance to terminals 3 and 4 and terminals 1 and 2. Switch S1 in the position II.

**Measurement range**

The resistance repeater can convey a maximum of 10 mA and a maximum of 7 V. The maximum connectable resistance value can be calculated with the following equations

- Resistance value = 4.2 V / measuring current
- Resistance value = 9 V / measuring current - 758 Ω

Use the smaller of these two resistance values as maximum allowed load.

The measuring current is determined by control.

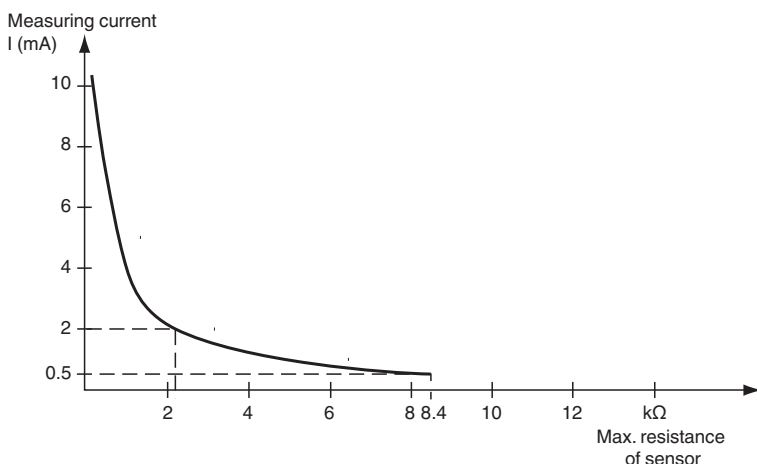

An example of the maximum transferable resistance value:

- 8.4 kΩ at 0.5 mA measuring current
- 2.1 kΩ at 2 mA measuring current

Release date 2015-04-27 13:37 Date of issue 2015-04-27 258075\_eng.xml

### Line Fault Detection (LFD)

The output will indicate less than 10  $\Omega$  or greater than 400  $\Omega$  for a lead breakage at terminals 1, 2, 3 or 4 for measuring current of less than or equal to 1 mA i.e. out of range for Pt100.

## Accessories

### Power feed module KFD2-EB2

The power feed module is used to supply the devices with 24 V DC via the Power Rail. The fuse-protected power feed module can supply up to 150 individual devices depending on the power consumption of the devices. Collective error messages received from the Power Rail activate a galvanically-isolated mechanical contact.

### Power Rail UPR-03

The Power Rail UPR-03 is a complete unit consisting of the electrical insert and an aluminium profile rail 35 mm x 15 mm. To make electrical contact, the devices are simply engaged.

### Profile Rail K-DUCT with Power Rail

The profile rail K-DUCT is an aluminum profile rail with Power Rail insert and two integral cable ducts for system and field cables. Due to this assembly no additional cable guides are necessary.



*Power Rail and Profile Rail must not be fed via the device terminals of the individual devices!*